

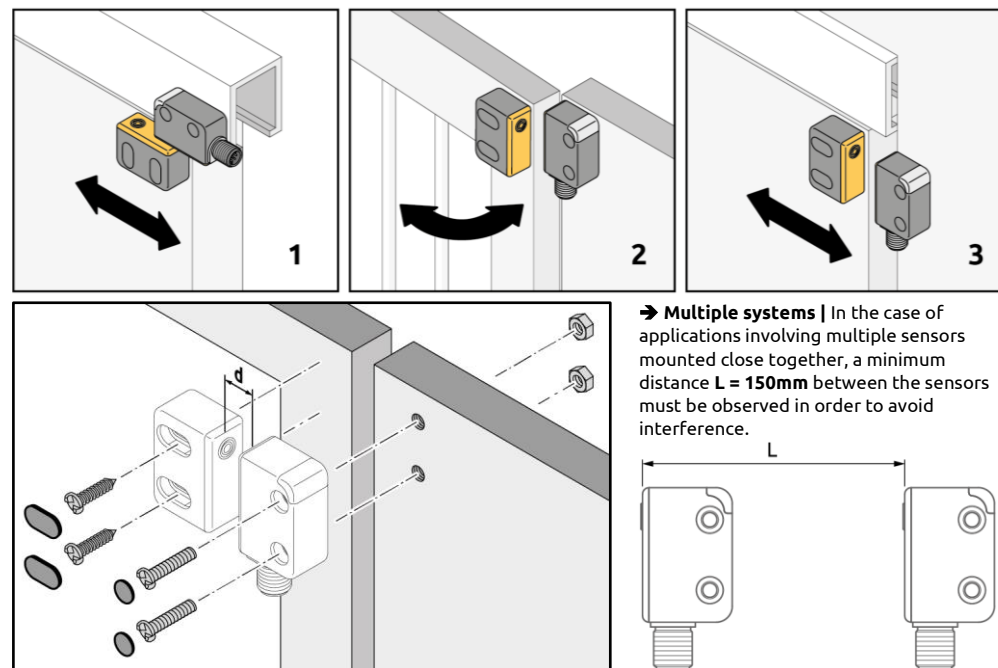

- I CONTENUTO IMBALLO**
Sensore | Attuatore | Sensore+Attuatore RFID.
Tappi di sicurezza. Guida di installazione.
- EN PACKAGE CONTENTS**
RFID Sensor | Actuator | Sensor+Actuator.
Safety caps. Quick installation guide.
- FR CONTENUE DE L'EMBALLAGE**
Capteur | Actuateur | Capteur+Actuateur RFID.
Caps de sécurité. Guide d'installation.
- D PACKUNGSINHALT**
RFID-Sensor | Aktuator | Sensor+Aktuator.
Sicherheitskappen. Installationsanleitung.
- E CONTENIDO DEL L'EMBALAJE**
Sensor | Actuador | Sensor+Actuador RFID.
Tapones de seguridad. Guía de instalación.



➔ **Multiple systems** | In the case of applications involving multiple sensors mounted close together, a minimum distance $L = 150\text{mm}$ between the sensors must be observed in order to avoid interference.

I	Per installare e utilizzare in modo corretto e sicuro il sensore RFID, è NECESSARIO consultare il manuale contenuto all'URL:	 www.reersafety.com/QR/8541641
EN	To guarantee a correct and safe installation and operation of the RFID sensor, it is MANDATORY to consult the user manual contained at URL:	
FR	Pour installer et utiliser correctement et en sécurité le capteur RFID, il est NECESSAIRE de consulter le manuel d'instruction, contenu à l'URL:	
D	Um den RFID-Sensor korrekt und sicher zu installieren und zu verwenden, MÜSSEN Sie das Handbuch unter der URL konsultieren:	
E	Para instalar y utilizar el sensor RFID de forma correcta y segura, DEBE consultar el manual que se encuentra en la URL:	

A) MONTAGGIO MECCANICO - MECHANICAL ASSEMBLY - MONTAGE MECANIQUE - BEFESTIGUNG - MONTAJE MECÁNICO

Precautions | Important

- Before installing the product, it is important to perform a specific risk analysis in accordance with the requirements of the Machinery Directive (2006/42/EC).
- REER guarantees the functional safety of R-Safe RFID but is not responsible for the performance of the system in which it is installed.
- Respect the correct activation direction described below.
- Remove power supply from the product before proceeding with mechanical installation.
- It is not permitted to fix sensor and actuator with less than two screws (EN ISO 14119).
- Follow the installation rules described in the standard EN ISO 14119.
- The use of anti-unscrewing screws is mandatory (EN ISO 14119).
- Fasten the devices to the gate using M4 x 20 screws or alternatively 3.5 x 19 cylinderhead self-threading screws with a tightening torque of 0.8 ... 1.5Nm.
- ➔ Mount the sensor to the fixed part of the safety gate/door and the actuator to the moving part.
- ➔ At the end of the assembly, plug the supplied caps into the housing of the fixing screws as shown in the assembly diagram. These plugs reduce the risk of tampering with the product as indicated in the EN ISO 14119 standard.
- ➔ Place the sensor and actuator facing each other with the centering marks at a distance d corresponding to:
Actuation direction 1: $6\text{mm} < d < 10\text{mm}$ | Actuation direction 2 and 3: $2\text{mm} < d < 10\text{mm}$
(See following pictures for actuation direction and distance d)

B) COLLEGAMENTI - CONNECTIONS - BRANCHEMENTS - ANSCHLÜSSE - CONEXIONES

- ➔ Carry out all connections before supplying power to the product.
- ➔ The ground connection (0VDC) must be common to all system components.
- ➔ Make sure that the connector is screwed in all the way to ensure correct operation of the product.
- ➔ The R-Safe RFID sensor must be supplied with a voltage of 24VDC +/- 20% (IEC 60947-5-2).
- ➔ Conductor size: 0.25 ... 2.5 mm².
- ➔ We recommend the use of separate power supplies for the product and for other electrical power equipment (electric motors, inverters, frequency converters) or other sources of disturbance.
- ➔ For connections longer than 20m, use cables with a cross-section of at least 0.5mm² (AWG16), (1mm² over 50m).



N.	COLOR	SIGNAL	DESCRIPTION
1	Brown	24VDC	24VDC power supply
2	White	INPUT1	OSSD input for serial connection 1
3	Blue	0VDC	0VDC power supply
4	Black	OSSD1	Safety output OSSD1
5	Grey	STATUS	Sensor status output
6	Pink	INPUT2	OSSD input for serial connection 2
7	Violet	OSSD2	Safety output OSSD2
8	Orange	EDM/ RESTART/ SERIAL	Feedback K1K2 / Restart / Serial connection input

N.	COLOR	SIGNAL	DESCRIPTION
1	Brown	24VDC	24VDC power supply
2	White	OSSD1	Safety output OSSD1
3	Blue	0VDC	0VDC power supply
4	Black	OSSD2	Safety output OSSD2
5	Grey	STATUS	Sensor status output

C) SCHEMI DI CONNESSIONE - WIRING DIAGRAMS - SCHÉMAS ÉLECTRIQUES - SCHALTPLÄNE - ESQUEMAS DE CONEXIÓN

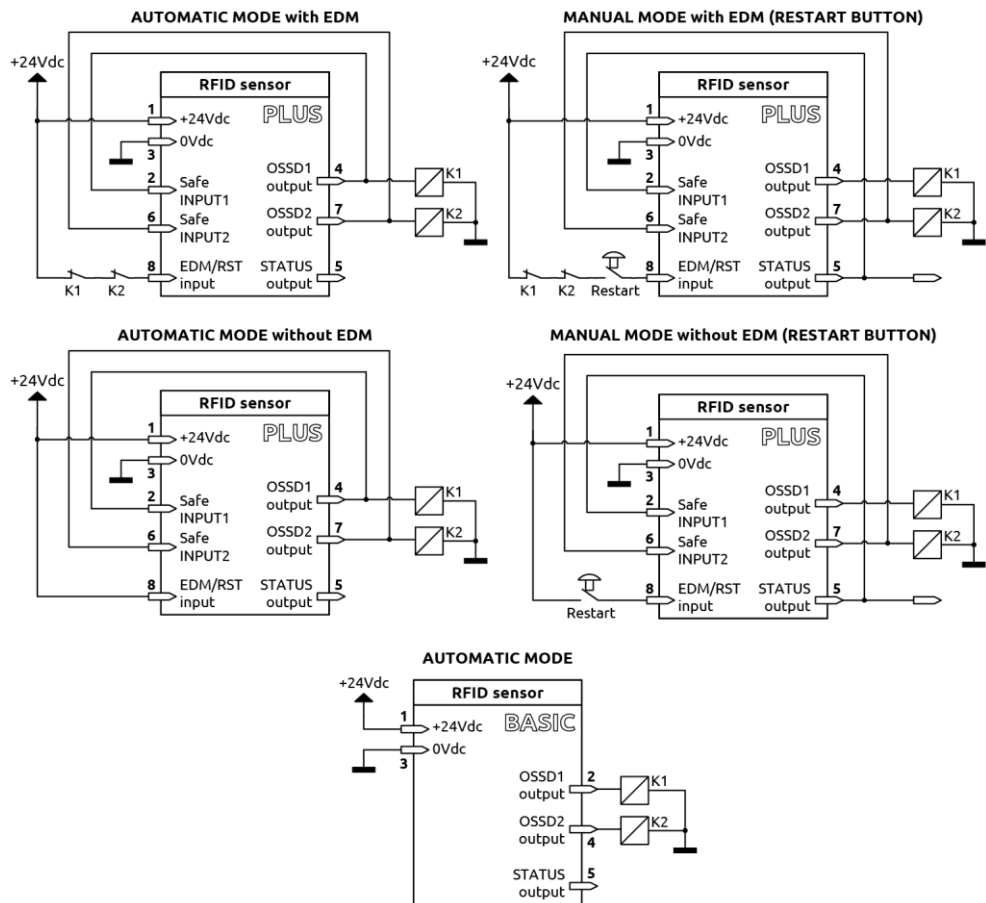

D) SEGNALAZIONI - STATUS INDICATORS - INDICATEURS - STATUSANZEIGEN - INDICADORES DE ESTADO

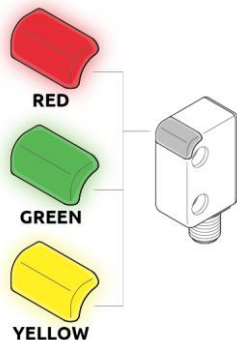

CONFIGURATION MODE (at power up)		
COLOR	BLINKING	MEANING
YELLOW blinking	2 times	Single sensor with EDM in AUTO mode
	3 times	Single sensor without EDM in AUTO mode
	4 times	Single sensor in MANUAL mode
	5 times	First sensor of serial connection
	6 times	Sensor of serial connection
NORMAL OPERATION		
COLOR	SENSOR STATUS	MEANING
RED	BREAK	OSSD outputs LOW
GREEN	GUARD	OSSD outputs HIGH
YELLOW	RESTART	Waiting for Restart
GREEN / RED blinking	GUARD / INPUT OFF	At least one sensor is in BREAK state
GREEN blinking	PROGRAMMING	Actuator programming (TEACH-IN)
YELLOW blinking	CONFIG	Configuration type (see table above)
RED blinking	FAIL	Error condition (see following table)

E) DIAGNOSTICA - DIAGNOSTICS - DIAGNOSTIC - DIAGNOSE - DIAGNÓSTICO

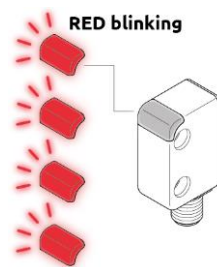

CONFIGURATION MODE (at power up)				
COLOR	BLINKING	ERROR (DIAGNOSTIC)	CORRECTIVE ACTION	
RED blinking	1 time	OSSD outputs error	Check OSSD connections (4, 7)	
	2 times	Safety input incongruency	Check sensor series connections (Input 2, 6 / OSSD 4, 7)	
	3 times	EDM error	Check EDM connections (8)	
	4 times	Overvoltage detected	Check connections / Send product to ReeR	
	5 times	Internal error	Send product to ReeR	
	6 times	Wrong transponder (actuator)	Replace actuator	
	7 times	Incorrect wire Configuration	Check connections	
	10 times	Antenna overvoltage detected	Send product to ReeR	

F) MODO SERIALE - SERIAL MODE - MODE SÉRIEUX - SERIENMODUS - MODO EN SERIE

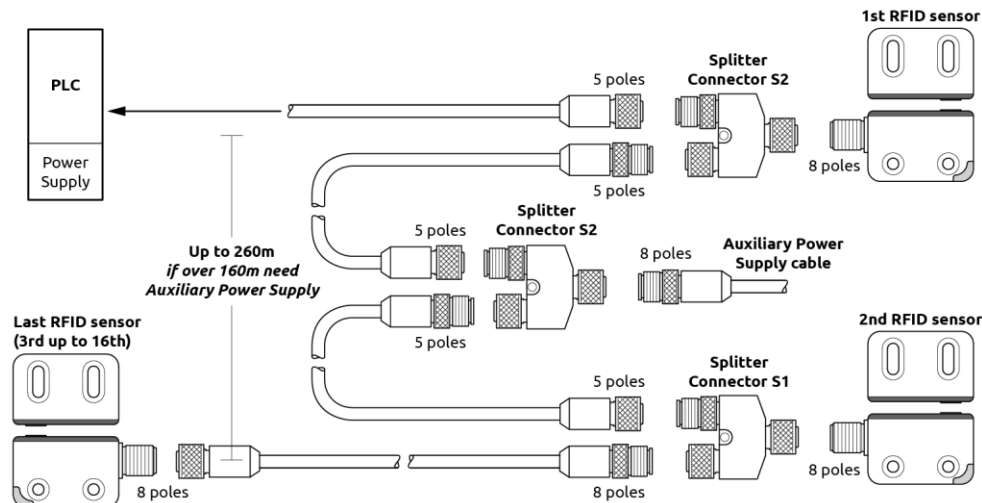

G) ASSEGNAZIONE NUOVO ID - NEW ID ASSIGNMENT - ATTRIBUTION NOUVEL ID - ZUTEILUNG NEUE ID - ASIGNACIÓN NUEVO ID

→ **ONLY TEACH-IN MODEL** - The sensor must be wired following the configuration in the diagram:

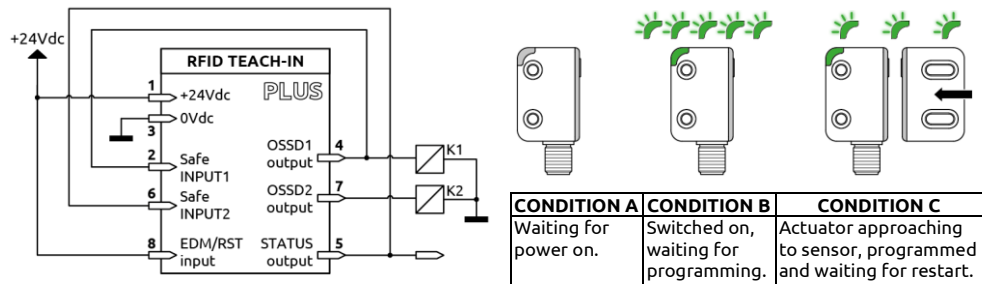

- I valori di sicurezza, i dati tecnici, le condizioni di garanzia e la Dichiarazione di Conformità sono contenute integralmente nel manuale.
- The safety values, technical data, warranty conditions and Declaration of Conformity are fully contained in the manual.
- Les valeurs de sécurité, caractéristiques techniques les conditions de garantie et la Déclaration de Conformité sont contenues dans le manuel dans leur intégralité.
- Die Sicherheitswerte, Technische Daten, Garantiebedingungen und Konformitätserklärung sind vollständig im Handbuch enthalten.
- Los valores de seguridad, datos técnicos, las condiciones de garantía y la Declaración de Conformidad se encuentran en el manual en su totalidad.