

User's guide

LDT10



RS-485 version



lika

Smart encoders & actuators

This publication was produced by Lika Electronic s.r.l. 2017. All rights reserved. Tutti i diritti riservati. Alle Rechte vorbehalten. Todos los derechos reservados. Tous droits réservés.

This document and information contained herein are the property of Lika Electronic s.r.l. and shall not be reproduced in whole or in part without prior written approval of Lika Electronic s.r.l. Translation, reproduction and total or partial modification (photostat copies, film and microfilm included and any other means) are forbidden without written authorisation of Lika Electronic s.r.l.

The information herein is subject to change without notice and should not be construed as a commitment by Lika Electronic s.r.l. Lika Electronic s.r.l. reserves the right to make all modifications at any moments and without forewarning.

This manual is periodically reviewed and revised. As required we suggest checking if a new or updated edition of this document is available at Lika Electronic s.r.l.'s website. Lika Electronic s.r.l. assumes no responsibility for any errors or omissions in this document. Critical evaluation of this manual by the user is welcomed. Your comments assist us in preparation of future documentation, in order to make it as clear and complete as possible. Please send an e-mail to the following address info@lika.it for submitting your comments, suggestions and criticisms.

The logo for Lika Electronic s.r.l. consists of the word "lika" in a bold, lowercase, sans-serif font. The letter 'i' has a dot above it. The logo is positioned in the bottom right corner of the page.

General contents



User's guide.....	1
General contents.....	3
Typographic and iconographic conventions.....	4
Preliminary information.....	5
1 Safety summary.....	6
1.1 Safety.....	6
1.2 Electrical safety.....	6
1.3 Mechanical safety.....	7
1.4 Precautions and usage tips.....	7
2 Identification.....	8
3 Mechanical installation.....	9
3.1 Overall dimensions (Figure 1).....	9
3.2 Mounting the panel (Figure 2).....	9
3.3 Cleaning the screen.....	11
4 Electrical connections.....	12
4.1 Connectors (Figure 3).....	13
4.2 Ground connection.....	15
4.3 Node address: Node ID.....	16
4.4 Data transmission rate: Baud rate and parity bit.....	17
5 HMI interface.....	18
5.1 Preliminary information.....	18
5.2 Starting the interface for the first time.....	19
5.3 Safety levels.....	19
5.3.1. Level 0 - User.....	21
5.3.2 Level 1 - Manager.....	21
5.3.3 Level 2 - Administrator.....	22
5.4 Network setup page.....	23
5.5 Network page.....	25
5.6 Node control page.....	26
5.7 Node status page.....	29
5.8 Node setup page.....	30
Decimals.....	31
Backlash direction.....	32
Backlash step length.....	34
5.9 Advanced node setup page.....	35
5.10 Home page.....	37
5.11 Firmware upgrade.....	39

Typographic and iconographic conventions

In this guide, to make it easier to understand and read the text the following typographic and iconographic conventions are used:

- parameters and objects both of the device and the interface are coloured in **GREEN**;
- alarms are coloured in **RED**;
- states are coloured in **FUCSIA**.

When scrolling through the text some icons can be found on the side of the page: they are expressly designed to highlight the parts of the text which are of great interest and significance for the user. Sometimes they are used to warn against dangers or potential sources of danger arising from the use of the device. You are advised to follow strictly the instructions given in this guide in order to guarantee the safety of the user and ensure the performance of the device. In this guide the following symbols are used:

	This icon, followed by the word WARNING , is meant to highlight the parts of the text where information of great significance for the user can be found: user must pay the greatest attention to them! Instructions must be followed strictly in order to guarantee the safety of the user and a correct use of the device. Failure to heed a warning or comply with instructions could lead to personal injury and/or damage to the unit or other equipment.
	This icon, followed by the word NOTE , is meant to highlight the parts of the text where important notes needful for a correct and reliable use of the device can be found. User must pay attention to them! Failure to comply with instructions could cause the equipment to be set wrongly: hence a faulty and improper working of the device could be the consequence.
	This icon is meant to highlight the parts of the text where suggestions useful for making it easier to set the device and optimize performance and reliability can be found. Sometimes this symbol is followed by the word EXAMPLE when instructions for setting parameters are accompanied by examples to clarify the explanation.

Preliminary information

This guide is designed to describe the technical characteristics, installation and use of the **LDT10 HMI touch panel for Lika's DRIVECOD intelligent rotary actuators**.

LDT10 is engineered to interface, set up and operate the whole series of RD rotary actuators with RS-485 MODBUS interface. It is intended to connect one single actuator (point-to-point connection), several actuators in the network (up to 8 actuators) and even different actuator models in the same network (RD1xA, RD4, RD5x and RD6 actuators can be installed and operate together).

The interface allows:

- to create a network of devices and configure the networked actuators;
- to collect data on the specific production (i.e. the work cycle of each actuator, its travel, ...) and save in recipes the information on each process;
- to manage the saved recipes and launch the program in order to activate the automatic change-over operation and start the new production.

LDT10 is specifically engineered to make change-over operations faster and easier, cut set-up time and reduce downtime, especially when small-batches, one-off items and just-in-time productions need frequent and costly format adjustments. The automated multi-axis systems such as in the plastics industry, mold changers, mobile stops, the packaging lines and the woodworking machines are a typical example.

Please note that the present manual implies a perfect knowledge of the user's guide of the RD rotary actuators it has to be connected to. Please read carefully the specific documentation before installing, connecting and operating the actuators. Refer to the manuals describing the MODBUS interface models (MAN RDx MB). Please download the complete technical documentation of the RD rotary actuators at www.lika.biz > ROTARY ACTUATORS > ROTARY ACTUATORS / POSITIONING UNITS (DRIVECOD).

For detailed technical specifications please consult the product datasheet.

To make it easier to read the text, this guide can be divided into two main sections.

In the first section general information concerning the safety, the mechanical installation and the electrical connection as well as tips for setting up and running properly and efficiently the touch panel are provided.

In the second section, entitled **HMI interface**, both general and specific information is given on the interface. In this section the interface features and the implemented functions are fully described.

1 Safety summary



1.1 Safety

- Always adhere to the professional safety and accident prevention regulations applicable to your country during device installation and operation;
- installation and maintenance operations have to be carried out by qualified personnel only, with power supply disconnected and stationary mechanical parts;
- device must be used only for the purpose appropriate to its design: use for purposes other than those for which it has been designed could result in serious personal and/or the environment damage;
- high current, voltage and moving mechanical parts can cause serious or fatal injury;
- warning! Do not use in explosive or flammable areas;
- failure to comply with these precautions or with specific warnings elsewhere in this manual violates safety standards of design, manufacture, and intended use of the equipment;
- Lika Electronic assumes no liability for the customer's failure to comply with these requirements.



1.2 Electrical safety

- Turn off the power supply before connecting the device;
- connect the device according to the explanation in the "Electrical connections" section on page 12;
- a safety push-button for emergency power off has to be installed to shut off the motor power supply in case of emergency situations;
- in compliance with the 2014/30/EU norm on electromagnetic compatibility, the following precautions must be taken:
 - before handling and installing the equipment, discharge electrical charge from your body and tools which may come in touch with the device;
 - power supply must be stabilized without noise; install EMC filters on device power supply if needed;
 - always use shielded cables (twisted pair cables whenever possible);
 - avoid cables runs longer than necessary;
 - avoid running the signal cable near high voltage power cables;
 - mount the device as far as possible from any capacitive or inductive noise source; shield the device from noise source if needed;



- to guarantee a correct working of the device, avoid using strong magnets on or near by the unit;
- minimize noise by connecting the device to ground. Make sure that ground is not affected by noise. Use the pin 3 available in the 3-pin connector **1** (refer to the "Electrical connections" section on page 12).



1.3 Mechanical safety

- Install the device following strictly the information in the "Mechanical installation" section on page 9;
- mechanical installation has to be carried out with stationary mechanical parts;
- do not disassemble the unit;
- do not tool the unit;
- delicate electronic equipment: handle with care; do not subject the device to knocks or shocks;
- respect the environmental characteristics of the product.



1.4 Precautions and usage tips

- This panel is intended for indoor use only;
- it is designed for a recessed installation into an industrial electrical cabinet;
- ensure that enough free space is left at the rear to allow the air circulation. Ensure that 200 mm / 7.87" of free space is left all around. When you mount the panel make sure that the air openings are not obstructed;
- the panel weight is indicated in the "Mechanical installation" section in this manual; make sure that the panel installation does not cause the electrical cabinet or support to become unstable;
- do not scratch the touch screen; do not use pens, pencils or sharp objects to touch the screen;
- the screen only needs soft touches for activation. Do not exert pressure on the screen;
- for further information on usage precautions and maintaining and cleaning the screen please refer also to the "3.3 Cleaning the screen" section on page 11.

2 Identification

The device can be identified through the **order code** and the **serial number** printed on the label applied to its enclosure. The information is listed in the delivery document too. Please always quote the order code and the serial number when reaching Lika Electronic for purchasing spare parts or needing assistance. For any information on the technical characteristics of the product refer to the technical catalogue.



Warning: devices having order code ending with "/Sxxx" may have mechanical and electrical characteristics different from standard and be supplied with additional documentation for special connections (Technical info).

3 Mechanical installation



WARNING

Installation and maintenance operations have to be carried out by qualified personnel only, with power supply disconnected and mechanical parts compulsorily in stop.

3.1 Overall dimensions (Figure 1)

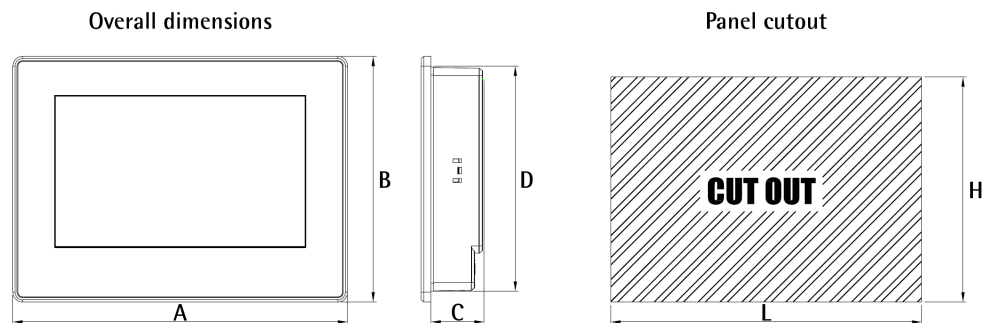

Figure 1 - LDT10 lay-out

	A	B	C	D	L	H
LDT10	204.4 mm 8.04"	151 mm 5.94"	26.5 mm 1.04"	137 mm 5.40"	191.5 mm 7.54"	138 mm 5.43"

Weight: 650 g / 22.9 oz.

3.2 Mounting the panel (Figure 2)

LDT10 touch panel is designed for a recessed installation into an industrial electrical cabinet or a panel assembly so that only the touch screen front panel can be accessed by the operator.

The touch panel must be mounted in a flat surface, at a position that is ergonomic for the operator and at a proper mounting height.

Ensure that enough free space is left at the rear to allow the air circulation. Ensure that 200 mm / 7.87" of free space is left all around. When you mount the panel make sure that the air openings are not obstructed.

To fix the touch panel cut a rectangular hole in the installation support. Use the dimensions as shown in Figure 1 and in the table above to provide the rectangular mounting cutout. Remove the burrs made while cutting. Mount the panel through the enclosure cutout without the mounting clips. Install the mounting clips at the four corners in the back of the panel (Figure 2) and then tighten the screws until the display is fixed properly.

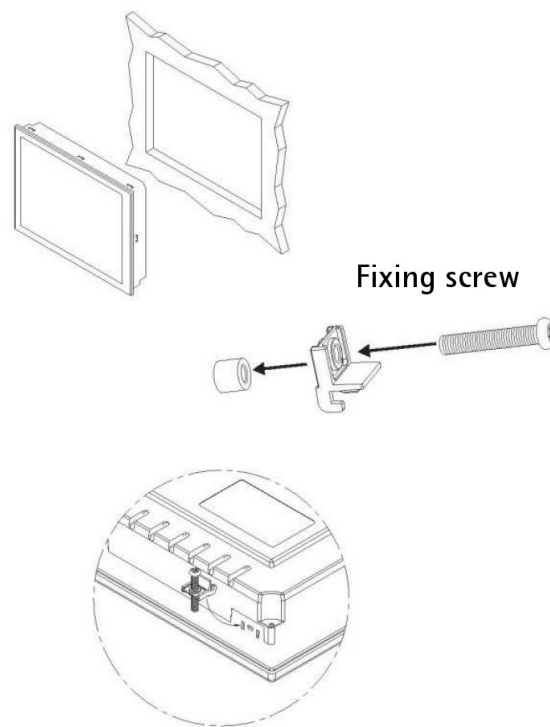

Figure 2 - Panel mounting

3.3 Cleaning the screen

**WARNING**

Switch the power supply off before cleaning the front screen.

Always use a soft and clean cloth such as a microfibre or cotton cloth to remove the dust from the display. Gently wipe the surface without exerting any pressure.

Should it be necessary to use a liquid to remove persistent stains or fingerprints, lightly dampen the cloth with water (distilled or demineralized water is suggested) or isopropyl alcohol.

Do not use abrasive fabrics or materials such as paper towels even though they are soft as they can scratch the display.

Do not use chemical agents and products that are generally used for cleaning, methylated spirit or ammonia as they could damage the screen surface and make marks.

**WARNING**

Solvents and abrasive materials could damage the display. Do not rub or brush the surface. Do not use aggressive and/or flammable products to clean the screen.

4 Electrical connections



WARNING

Power supply must be turned off before performing any electrical connection!

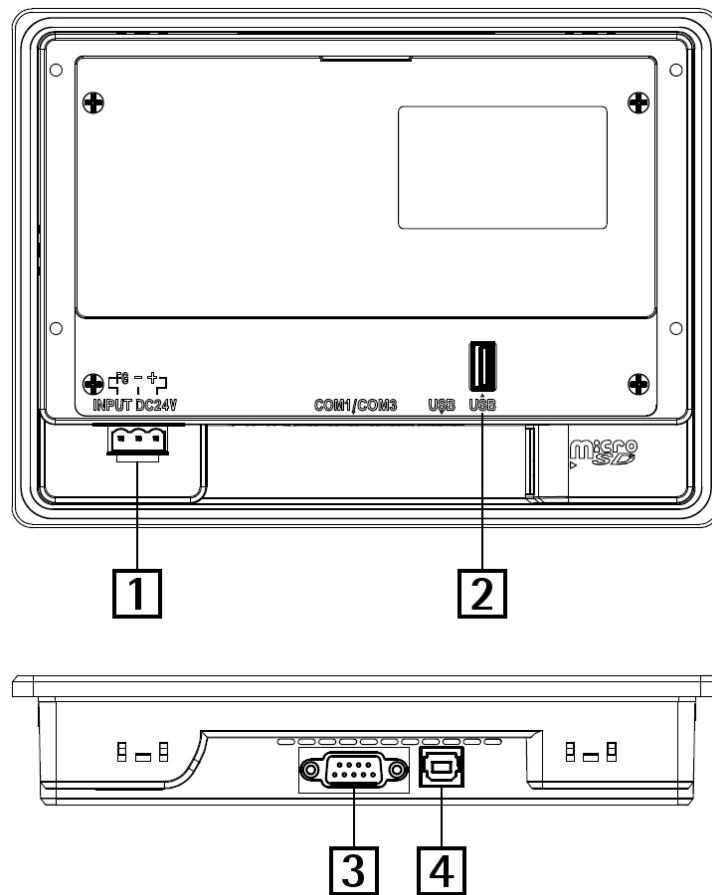

Figure 3: Electrical connections

1	3-pin connector – Power supply
2	USB service port – Firmware upgrade (see on page 39)
3	DSub 9-pin female RS-485 COM1 port – MODBUS interface
4	Reserved USB port – Not used

4.1 Connectors (Figure 3)

LDT10

Power supply

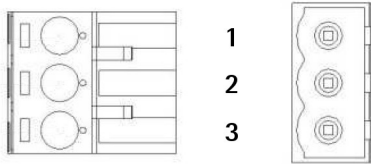
3-pin connector		Pin	Function
	1	1	+24Vdc power supply
	2	2	0 Vdc power supply
	3	3	GND

RS-485 COM1 serial port – MODBUS interface

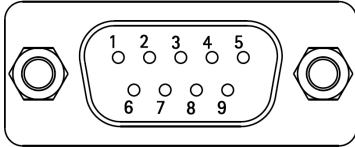
Dsub 9-pin female		Pin	Function
	1	1	MODBUS A (RS-485)
	6	6	MODBUS B (RS-485)
	2 ... 5		Not connected
	7 ... 9		Not connected

RD1A - RD12A

Power supply

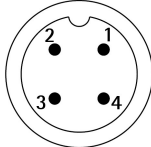
M12 4-pin male connector A coding		Pin	Function
	1	1	+24Vdc ±10% motor
	2	2	+24Vdc ±10% controller
	3	3	0 Vdc motor and controller
	4	4	Not connected

RS-485 MODBUS interface

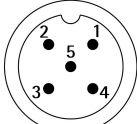
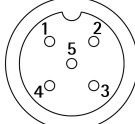
M12 5-pin connector A coding		Pin	Function
BUS IN male		1 - 2	Not connected
		3	GND (RS-485)
BUS OUT female		4	MODBUS A (RS-485)
		5	MODBUS B (RS-485)

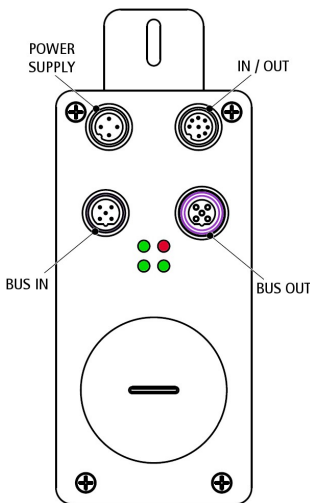

RD4

Power supply

M16 3-pin male connector A coding	Pin	Function
	1	+24Vdc ±10% motor
	2	+24Vdc ±10% controller
	3	0 Vdc motor and controller

RS-485 MODBUS interface

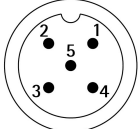
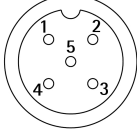
M12 5-pin connector A coding	Pin	Function
BUS IN male	1 - 2	Not connected
	3	GND (RS-485)
	4	MODBUS A (RS-485)
	5	MODBUS B (RS-485)
	BUS OUT female	
		

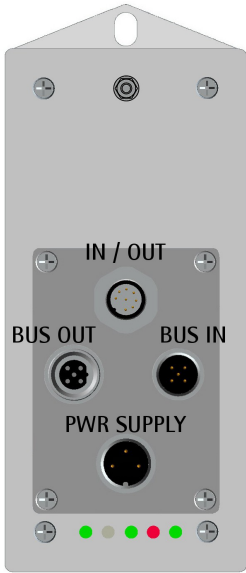

RD5 - RD52

Power supply

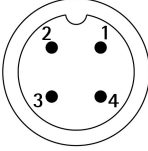
M12 4-pin male connector A coding	Pin	Function
	1	+24Vdc ±10% motor
	2	+24Vdc ±10% controller
	3	0 Vdc motor and controller
	4	Not connected

RS-485 MODBUS interface

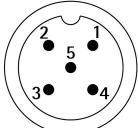
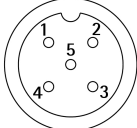
M12 5-pin connector A coding	Pin	Function
BUS IN male	1 - 2	Not connected
	3	GND (RS-485)
	4	MODBUS A (RS-485)
	5	MODBUS B (RS-485)
	BUS OUT female	
		

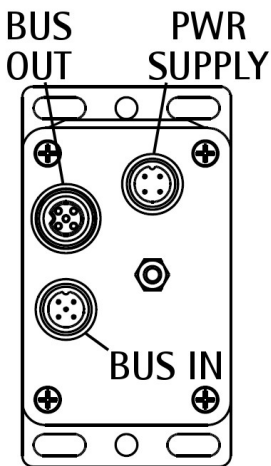

RD6

Power supply

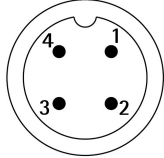
M18 4-pin male connector	Pin	Function
	1	+24Vdc ±10% motor
	2	+24Vdc ±10% controller
	3	0 Vdc motor
	4	0 Vdc controller

RS-485 MODBUS interface

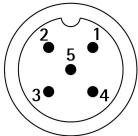
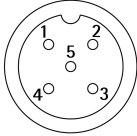
M12 5-pin connector A coding	Pin	Function
BUS IN male	1 - 2	Not connected
	3	GND (RS-485)
	4	MODBUS A (RS-485) High, +
	5	MODBUS B (RS-485), Low, -
BUS OUT female		
		

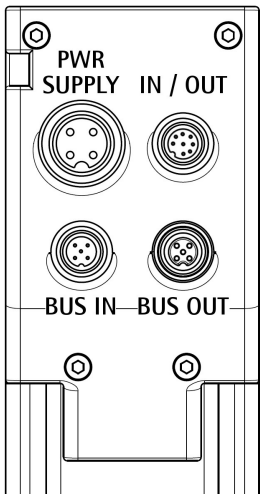

WARNING

For comprehensive information on the electrical connection of the DRIVECOD rotary actuators please refer to the specific documentation regarding the MODBUS interface models.

4.2 Ground connection

Minimize noise by connecting the panel to ground. We suggest using the ground point provided through the pin 3 in the 3-pin connector 1 (Figure 3). Make sure that ground is not affected by noise and as close to the device as possible.

4.3 Node address: Node ID

The MODBUS Serial Line protocol is a Master – Slaves protocol. One only Master (at the same time) is connected to the bus and one or several Slave nodes are also connected to the same serial bus. A MODBUS communication is always initiated by the Master. The Slave nodes will never transmit data without receiving a request from the Master node. The Slave nodes will never communicate with each other. The Master node initiates only one MODBUS transaction at the same time.

LDT10 HMI interface is a MODBUS Master device, the networked actuators are Slave nodes, so they must be provided with an univocal address. Lika devices support the UNICAST mode, so the Master node issues a MODBUS request to an individual Slave.

Before networking a device, the univocal address must be set. **The node address is set via hardware in each device by using the dip switches** located inside the enclosure. LDT10 interface allows to network up to 8 actuators; their address has to be in the range from 1 to 8. For more information on setting the node address please refer to the specific documentation regarding the MODBUS interface models.

In the **Network setup** page it is possible to match the networked actuators with the interface; as stated, their address has to be between 1 and 8. The device having the physical address 1 must be compulsorily matched with the **Actuator 1** position; the device having the physical address 2 must be compulsorily matched with the **Actuator 2** position; and so on. For more information refer also to the "5.4 Network setup page" section on page 23.



WARNING

In the **Network setup** page if you match a node with a wrong position (for instance you match the **Actuator 2** position with an actuator having an address different from "2"), then the communication cannot be established and the following **COMMUNICATION ERROR** message will appear on the display.



WARNING

If the rotary actuator is either the first or the last device in the network (i.e. it is installed at the ends of the network), the provided RT bus termination resistor has to be activated as line termination. Use the RT switch located inside the actuator's enclosure to activate or deactivate the bus termination. For detailed information please refer to the specific documentation of the actuator.

4.4 Data transmission rate: Baud rate and parity bit

HMI LDT10 interface allows 9600 bits/s data transmission rate with "Even" parity bit. Different baud rates are not supported.



WARNING

DRIVECOD rotary actuators are fitted with a hardware switch designed to set the baud rate and the parity bit. It is located inside the actuator's enclosure. As their default setting is "1000", that is: baud rate = 9600 bits/s, parity bit = Even, no further setting is usually required. If you are going to integrate a previously networked actuator, please check that the baud rate and the parity bit switch is set to "1000". For detailed information please refer to the documentation of the specific actuator.

5 HMI interface

5.1 Preliminary information

Except for the first time the panel is started (for this case please refer to the "5.2 Starting the interface for the first time" section here below), at power-on the **Home** page appears on the display. From the **Home** page you can enter the full set of pages of the interface, provided that you comply with the protection level L required by the page. For more information see the below scheme and refer to the "5.3 Safety levels" section on page 19.

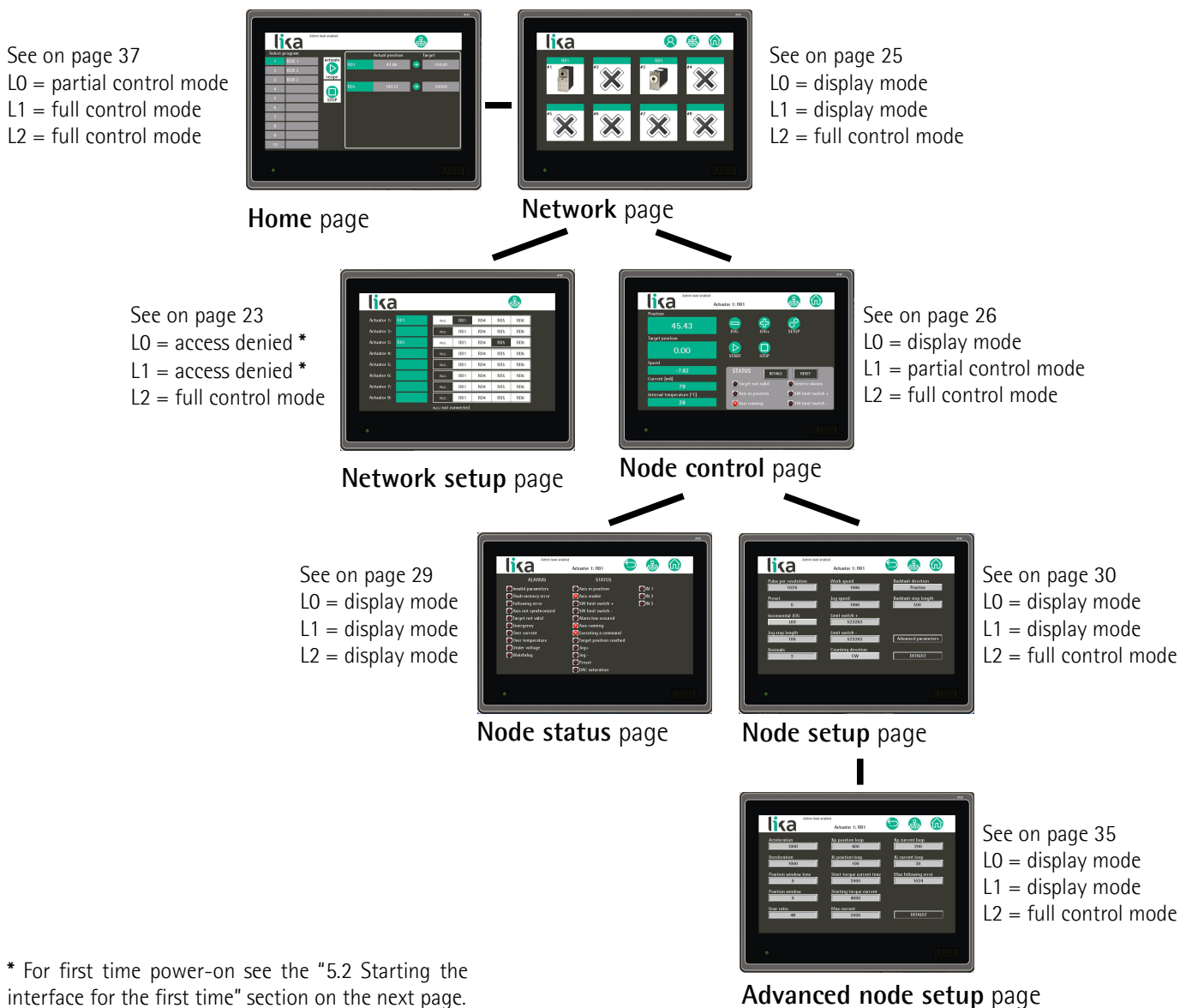

5.2 Starting the interface for the first time

When you start the interface for the first time, the system displays the **Network setup** page. In normal work condition this page can be accessed only by Level 2 – Administrator users while Level 0 – User and Level 1 – manager users (see the "5.3 Safety levels" section on page 19) are not allowed. Yet in this first phase as it is compulsorily necessary to match one actuator at least with the interface, the system enables also the Level 0 users and the Level 1 users to enter the page and match the connected devices with the node positions. Once you install one



actuator in the page, after pressing the key and exiting the page, any further access will be allowed to the Level 2 – Administrator users only. Otherwise, if no configuration is made, the **Network setup** page will be displayed again at next power-on.

For complete information on the **Network setup** page please refer to the "5.4 Network setup page" section on page 23.



5.3 Safety levels

The interface provides three safety levels. In some cases they restrict the usage permissions or prevent the users from entering the pages or accessing some functions available in the pages.

The three levels are:

- **L0 level 0 = User level;**
- **L1 level 1 = Manager level;**
- **L2 level 2 = Administrator level.**

The access to the functions of the basic level 0 is free and does not require any password. While the access to the functions of the level 1 and the level 2 requires a password to be entered. **Passwords cannot be modified.**

To enter a password, you must first access the **Network** page (see on page 25)

and then press the  key in the menu at the top of the page. As soon as you press the key, the following on-screen numeric keypad will appear:



- Enter the Level 1 – Manager password ("1122", see the "5.3.2 Level 1 – Manager" section on page 21) to gain access to the functions of the level 1;
- enter the Level 2 – Administrator password ("2233", see the "5.3.3 Level 2 – Administrator" section on page 22) to gain access to the functions allowed for the level 2.

Confirm by pressing the **ENT** key. To enter back the basic User level press the

 key again.

The protection level that is currently enabled is shown in the message in the menu at the top of the page:

- no message: level 0 - User;
- **"Manager level enabled"**: level 1 - Manager enabled;
- **"Admin level enabled"**: level 2 - Administrator enabled.



NOTE

Should you type a wrong digit while entering the password, press the **ESC** key in the keypad to exit the digit entry mode, then repeat the operation.

5.3.1. Level 0 - User

It is the first security level and allows for a basic use of the interface. It does not require a password and is mainly aimed at the users that are involved in the production process. In this level the user is allowed to display most of the pages and to launch the recipes in order to start a production.

In particular the "User" level allows:

- to enter the **Home** page yet not to make changes in the stored recipes;
- to display the **Network** page yet not to enter the **Network setup** page;
- to display the device configuration parameters in the **Node control**, **Node setup** and **Advanced node setup** pages yet not to change the set values.



WARNING

When you start the interface for the first time, as it is compulsorily necessary to match one actuator at least with the interface, the system allows also the Level 0 and Level 1 users to enter the **Network setup** page and match the available devices with the node positions. For comprehensive information please refer to the "5.2 Starting the interface for the first time" section on page 19.



NOTE

When the Level 0 - User is enabled, no message appears in the white background menu at the top of the page.

5.3.2 Level 1 - Manager

This is the intermediate safety level. It allows a more complete use of the recipes-related functions yet it prevents the network and the actuator parameters from being operated. To enter the intermediate level 1 - Manager you must digit the password "1122". The "**Manager level enabled**" message appears in the white background menu at the top of the page.

The "Manager" level allows:

- to enter the **Home** page and make changes in the stored recipes (name and targets of every recipe);
- to display the **Network** page yet not to enter the **Network setup** page;
- to enter the **Node control** page and execute the jog, start, stop and reset functions; yet not to change the parameters set in the actuator (ppr, preset, SW limit, ...);
- to display the parameters in the **Node setup** and **Advanced node setup** pages yet not to change any of them.

**WARNING**

When you start the interface for the first time, as it is compulsorily necessary to match one actuator at least with the interface, the system allows also the Level 0 and Level 1 users to enter the **Network setup** page and match the available devices with the node positions. For comprehensive information please refer to the "5.2 Starting the interface for the first time" section on page 19.

5.3.3 Level 2 - Administrator

This is the full control level and allows to access all the interface functions, for this reason it is aimed at the installer and/or the system/network manager who have competent knowledge, skills and experience. To activate the level 2 functions you must enter the password "**2233**". The "**Admin level enabled**" message appears in the white background menu at the top of the page.

The "Administrator" level enables the full control of all the interface functions, in more detail it allows:

- to enter the **Home** page and make changes in the recipes (name and targets of every recipe);
- to display the **Network** page;
- to enter the **Network setup** page and make changes in the networked devices;
- to enter the **Node control** page and execute the jog, start, stop and reset functions; it further allows to change the parameters available in the page (ppr, preset, SW limit, ...);
- to enter the **Node setup** and **Advanced node setup** pages and change the set parameters.

5.4 Network setup page



WARNING

Level 2 – Administrator users only are allowed to manage the functions available in this page.

As previously stated, when you start the interface for the first time, the system displays the **Network setup** page. In normal work condition this page can be accessed only by Level 2 – Administrator users while Level 0 – User and Level 1 – manager users (see the "5.3 Safety levels" section on page 19) are not allowed. Yet in the first phase as it is compulsorily necessary to match one actuator at least with the interface, the system enables also the Level 0 and Level 1 users to enter the page and match the available devices with the node positions. For more information please refer to the "5.2 Starting the interface for the first time" section on page 19.



WARNING

Before networking a device, the univocal address must be set. The node address is set via hardware in each device by using the dip switches located inside the enclosure. LDT10 interface allows to network up to 8 actuators; their address has to be in the range from 1 to 8. For complete information please refer to the "4.3 Node address: Node ID" section on page 16.

The **Network setup** page allows to match the networked actuators with the interface. The address of the connected actuators has to be between 1 and 8. The device having the physical address 1 must be compulsorily matched with the **Actuator 1** position; the device having the physical address 2 must be compulsorily matched with the **Actuator 2** position; and so on. As the actuators have different and specific mechanical and electronic characteristics it is also

necessary to specify the actuator model that you are going to match with the node position.

For instance, if you need to install a RD1A-...-MB- actuator having "1" physical address then you must press the **RD1** key in the **Actuator 1** line and optionally enter a brief description (max. 8 digit long) in the field on the right of the **Actuator 1** label (the description will appear in all pages of the interface to identify the device having the node address 1). As soon as you press on the description field an on-screen alphanumeric keypad will appear on the display: enter the description and then press the **ENT** key to confirm. See the example in the Figure below.

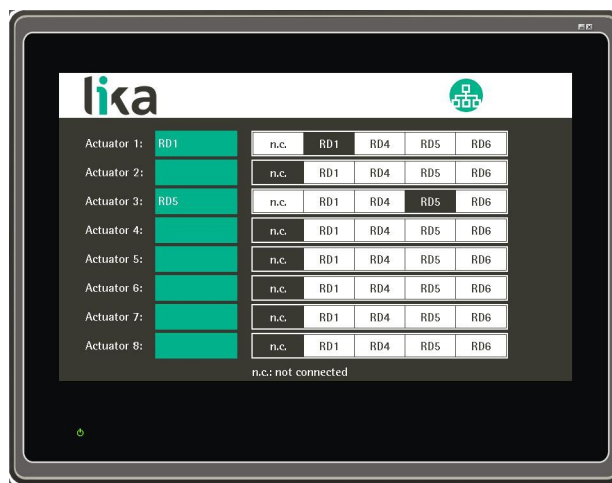

Press the  key to enter the **Network** page.

5.5 Network page

Press the  key to enter the **Network** page.



WARNING

All users are allowed to display this page yet some functions are available to the higher safety level users only (password protected levels).

The **Network** page is some sort of key point in the structure of the interface pages. It allows:

- to display the devices that are currently matched with the interface;
- to enter the passwords when required to access the protected pages or functions (for more information please refer to the "5.3 Safety levels" section on page 19);
- to enter the **Network setup** page;
- to move back to the **Home** page;
- to enter the **Node control** page which allows to further enter the **Node status**, the **Node setup** and the **Advanced node setup** pages.

Press the  key in the menu at the top of the page to enter a password when required and thus access the protected functions. For any information on the safety levels required to enter the interface pages please refer to the "5.3 Safety levels" section on page 19.



Press the  key in the menu at the top of the page to enter the **Network setup** page. For complete information please refer to the "5.4 Network setup page" section on page 23.



Press the  key in the menu at the top of the page to move back to the **Home** page. For any information refer to the "5.10 Home page" section on page 37.



Press the  icon available under all the active nodes to enter the **Node control** page; the **Node control** page further allows to enter the **Node status**, the **Node setup** and the **Advanced node setup** pages to set the parameters and check the status of each actuator. For any information please refer to the "5.6 Node control page" section on page 26.

5.6 Node control page



When you press the  icon available under all active nodes in the **Network** page, you enter the **Node control** page; the **Node control** page further allows to enter the **Node status**, **Node setup** and the **Advanced node setup** pages to set the parameters and check the status of each actuator. Please note that the displayed parameters and statuses specifically refer to the selected actuator (in the example below, the parameters and statuses are specific of the node 1 – Actuator 1).



**WARNING**

All users are allowed to display this page yet some functions are available to the higher safety level users only (password protected levels).

This page can be divided into three sections:

- on the left side section of the screen the parameters that are used to set the actuator's target are available; furthermore some results useful to check the operation of the actuator are available; the setting of the target is allowed to the level 1 and level 2 users only; please see below in this section;
- on the top-right side section of the screen the keys that are necessary to adjust the actuator's target are available; the keys are available to the level 1 and level 2 users only; please see below in this section; the  **SETUP** key is further available; it allows to display the **Node setup** page and access the list of some parameters that may be required sometimes to configure the actuator and the travel for the specific application (this function is available to the level 2 users only; see the "5.8 Node setup page" section on page 30). For a comprehensive description of the parameters please refer to the "User's guide" of the specific actuator;
- in the "Status" section on the bottom right of the screen the main alarms and statuses of the actuator are displayed; they are available in the "**Alarms**" register and in the "**Status Word**" of the device. Press the **DETAILS** key to enter the **Node status** page and display the full list of the available alarms and statuses (see the "5.7 Node status page" section on page 29). Press the **RESET** key (it is available to the level 1 and level 2 users only) to reset the Slave alarms and restore the normal work condition (provided that the fault condition has ceased; see the "**Alarm reset**" function in the "**Control Word**" of the device). For a comprehensive description of the alarms and statuses please refer to the "User's guide" of the specific actuator.

The functions described here below are available to the level 1 and level 2 users only.

The **Position** field is used to show the current position of the device expressed in pulses. See the "**Current position**" register in the "User's guide" of the specific actuator.

The **Target position** field allows to set the target position, i.e. the position that the actuator is commanded to reach. The value is expressed in pulses. See the "**Target position**" register in the "User's guide" of the specific actuator.

After having set the target position you can start and check the motion of the axle to the target position by pressing the following keys:

 **JOG -**,  **JOG +**,  **START** and  **STOP**.

After having set the required target position and reached it (**Position = Target position**), you can enter the **Home** page and then save the target position in

the wished recipe by pressing the  key.

For a comprehensive description of the JOG, START and STOP functions please refer to the "**Control Word**" register in the "User's guide" of the specific actuator.



WARNING

As soon as you press the **JOG** and **START** keys the axle starts moving. Before pressing the keys please make sure that the movement can be achieved with absolute safety and no risk to cause injuries to the operators and damages to the equipment can arise.



WARNING

Please note that pressing the **STOP** key will cause a normal and sequential halt of the actuator to be forced; the actuator will be commanded to stop respecting the set deceleration value; thus its stop will not be immediate.

Press the  key in the menu at the top of the page to enter the **Network** page. For complete information please refer to the "5.5 Network page" section on page 25.

Press the  key in the menu at the top of the page to move back to the **Home** page. For any information refer to the "5.10 Home page" section on page 37.

5.7 Node status page



WARNING

All users are allowed to display this page.

When you press the **DETAILS** key in the **Node control** page you enter the **Node status** page. In this page the complete list of the available alarms and statuses is displayed. The alarms and statuses currently active are highlighted by a red box that appears on the left side of the field. For a comprehensive description of the available alarms and statuses please refer to the "**Alarms**" and "**Status Word**" registers in the "User's guide" of the specific actuator.

To reset an alarm condition of the Slave device (provided that the fault condition has ceased) press the **RESET** key in the **Node control** page. The **RESET** key is available to the level 1 and level 2 users only. Refer also to the "**Alarm Reset**" function in the "**Control Word**" of the device.



Press the  key at the top of the page to enter the **Node control** page. For any information please refer to the "5.6 Node control page" section on page 26.

Press the  key at the top of the page to enter the **Network** page. For any information please refer to the "5.5 Network page" section on page 25.

Press the  key at the top of the page to move back to the **Home** page. For any information please refer to the "5.10 Home page" section on page 37.

5.8 Node setup page



WARNING

All users are allowed to display this page yet the functions are available to the Level 2 – Administrator users only.



When you press the **SETUP** key in the **Node control** page you enter the **Node setup** page. In the **Node setup** page the list of some actuator's programming parameters that may be required sometimes to configure the actuator and the travel for the specific application is available. For the list of the advanced parameters that are used to configure the mechanical and electronic characteristics of the specific actuator (for such reason they have seldom to be reprogrammed after the first configuration) press the **ADVANCED PARAMETERS** key in this page and enter the **Advanced node setup** page. Press on the field to set the desired value, a numeric keypad will appear on the screen. Confirm the entry by pressing the **OK** key.



As soon as you confirm the entry, if the entered value and any other setting are inconsistent, a red box appears on the left side of the fields.



All the parameters in this page are described in the "User's guide" of the specific actuator, for a comprehensive description please refer to it. Only three parameters are specific of the LDT10 interface, thus they are described hereafter.

Decimals

It sets the number of digits for the decimal places that are used to show the **Position** value, the **Target position** value and the **Speed** value in the **Home** and **Node control** pages. If the aforementioned parameters also appear in other pages, they are displayed without decimal places.

Default = 0 (min. value = 0, max. value = 4)

For example, if you set **Decimals** = 2, the **Position** value, the **Target position** value and the **Speed** value will be displayed with two decimal digits as shown in the Figure here below.

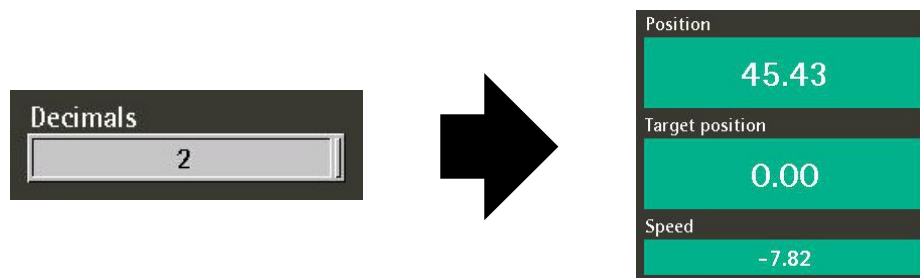



EXAMPLE

Let's suppose that the actuator is installed on a 5-mm pitch worm screw. If you set **Pulse per revolution** = 500 and **Decimals** = 2, at each rotation of the screw the system performs a 5-mm pitch with a resolution of one hundredth of a millimetre.



WARNING

As the setting of the decimal digits directly affects the calculation of the actuator's position, after confirming a new value please check and, if necessary, recalculate the target positions in all recipes.

Backlash direction

This parameter allows to enable the **unidirectional positioning function**. The unidirectional positioning function (backlash compensation) has to be used to compensate for (minimize) the effects of the backlash, i.e. the clearance or lost motion in the mechanism caused by gaps between the parts. As it is unidirectional, this parameter further allows to set whether the compensation is performed when the axle moves forwards (positive direction) or when it moves backwards (negative direction).

If **OFF** is set in this option, the function is disabled.

If **POSITIVE** is set in this option, the backlash compensation is performed only when the axle moves toward positive target by applying the value set in the next **Backlash step length** item.

If **NEGATIVE** is set in this option, the backlash compensation is performed only when the axle moves toward negative target by applying the value set in the next **Backlash step length** item.

When the **Backlash direction** function is enabled and active, the **BACKLASH ENABLED** message appears in the **Node control** page as the compensation is performed.

Default = OFF



Backlash, sometimes called lash or play, is clearance or lost motion in a mechanism caused by gaps between the parts. It can be defined as "the maximum distance or angle through which any part of a mechanical system may be moved in one direction without applying appreciable force or motion to the next part in mechanical sequence", and is a mechanical form of deadband. Backlash results in inaccurate calculation from the small error introduced at the change of direction and thus in wrong target achievement. The backlash compensation allows the system to automatically move the extra distance required to take up the slack when the axle changes direction so reaching the target position properly.

As shown in the figure below, if you set **Backlash direction = POSITIVE**, the backlash compensation is performed only when the axle moves toward positive target T1, it is not performed when the axle moves toward negative target T2 (P marks the starting position of the axle). The extra distance or gap that the travel has to be compensated for is set next to the **Backlash step length** item.

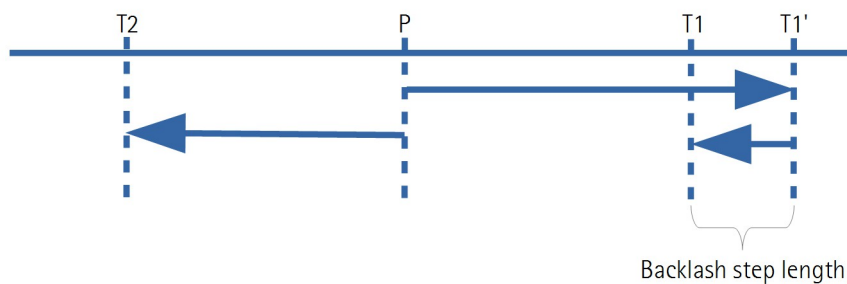

As shown in the figure below, if you set **Backlash direction = NEGATIVE**, the backlash compensation is performed only when the axle moves toward negative target T2, it is not performed when the axle moves toward positive target T1 (P marks the starting position of the axle). The extra distance or gap that the travel has to be compensated for is set next to the **Backlash step length** item.

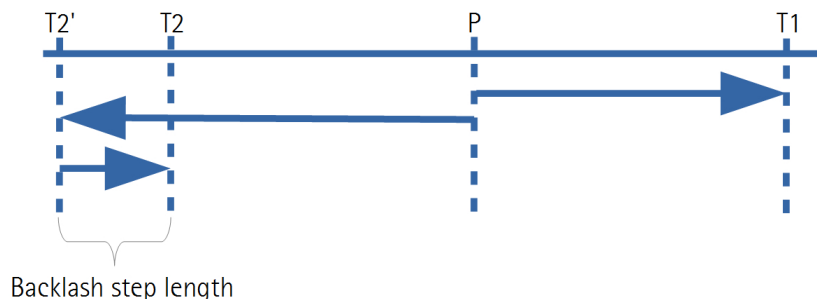

Backlash step length

This parameter sets the extra distance or gap that the travel has to be compensated for in order to minimize the backlash effects and reach the target position as precisely as possible. The value is expressed in pulses. For comprehensive information on the unidirectional positioning function (backlash compensation) please refer to the previous **Backlash direction** item.

Default = 0 (min. value = 0, max. value = 65535)

Press the **DEFAULT** key below right in the page to restore the default values of the actuator. Default parameters are set at the factory by Lika Electronic engineers to allow the operator to run the device for standard operation in a safe mode.



WARNING

DRIVECOD units are adjusted by performing a full-load mechanical running test; thence default values which has been set refer to an idle device, i.e. running disengaged from the load. Furthermore they are intended to ensure a standard and safe operation which not necessarily results in smooth running and optimum performance. Thus to suit the specific application requirements it may be advisable and even necessary to enter new parameters instead of the factory default settings; in particular it may be necessary to change velocity, acceleration, deceleration and gain values.



WARNING

As soon as you confirm the reset of all settings to factory defaults, all previously set parameters will be overwritten!



WARNING

As the reset to the defaults may affect the resolution values and so the calculation of the actuator's position, after using the function please check and, if necessary, recalculate the target positions in all recipes.



Press the  key in the menu at the top of the page to move back to the **Node control** page. For any information please refer to the "5.6 Node control page" section on page 26.



Press the  key at the top of the page to enter the **Network** page. For any information please refer to the "5.5 Network page" section on page 25.



Press the  key at the top of the page to move back to the **Home** page. For any information please refer to the "5.10 Home page" section on page 37.

Press the **ADVANCED PARAMETERS** key to enter the **Advanced node setup** page.

5.9 Advanced node setup page



WARNING

All users are allowed to display this page yet the functions are available to the Level 2 – Administrator users only.



By pressing the **ADVANCED PARAMETERS** key in the **Node setup** page you enter the **Advanced node setup** page. In this page the list of the advanced parameters that are used to configure the mechanical and electronic characteristics of the specific actuator (for such reason they have seldom to be reprogrammed after the first configuration) is available. All the parameters in this page are described in the "User's guide" of the specific actuator, for a comprehensive description please refer to it.

Enter the **Node setup** page to set the actuator's programming parameters that may be required sometimes to configure the actuator and the travel for the specific application.

Press the **DEFAULT** key below right in the page to restore the default values of the actuator. Default parameters are set at the factory by Lika Electronic engineers to allow the operator to run the device for standard operation in a safe mode.

**WARNING**

DRIVECOD units are adjusted by performing a full-load mechanical running test; thence default values which has been set refer to an idle device, i.e. running disengaged from the load. Furthermore they are intended to ensure a standard and safe operation which not necessarily results in smooth running and optimum performance. Thus to suit the specific application requirements it may be advisable and even necessary to enter new parameters instead of the factory default settings; in particular it may be necessary to change velocity, acceleration, deceleration and gain values.

**WARNING**

As soon as you confirm the reset of all settings to factory defaults, all previously set parameters will be overwritten!

**WARNING**

As the reset to the defaults may affect the resolution values and so the calculation of the actuator's position, after using the function please check and, if necessary, recalculate the target positions in all recipes.



Press the  key in the menu at the top of the page to move back to the **Node control** page. For any information please refer to the "5.6 Node control page" section on page 26.



Press the  key at the top of the page to enter the **Network** page. For any information please refer to the "5.5 Network page" section on page 25.



Press the  key at the top of the page to move back to the **Home** page. For any information please refer to the "5.10 Home page" section on page 37.

5.10 Home page

The **Home** page is displayed at power-on (see the only exception in the "5.2 Starting the interface for the first time" section on page 19) and allows to create and manage the recipes. It is mainly aimed at the users that are involved in the production process (Level 0 – User).



WARNING

All users of any safety level are allowed to launch the recipes in order to start a new production; Level 1 – Manager and Level 2 – Administrator users only are allowed to create new recipes and make changes in existing ones.



The word "recipe" means a program which allows to store the whole set of parameters necessary to configure all the devices intended for a work or production process.

In this application, all the parameters are specific to each actuator except for the target position; only the target position is specific to the recipe.

In the **Node setup** page the list of some actuator's programming parameters that may be required sometimes to configure the actuator and the travel for the specific application is available.

In the **Advanced node setup** page the list of the advanced parameters that are used to configure the mechanical and electronic characteristics of the specific actuator (for such reason they have seldom to be reprogrammed after the first configuration) is available.

After having configured each actuator by properly setting the parameters in the **Node control**, **Node setup** and **Advanced node setup** pages, it is possible to create a recipe.

If you need, for instance, to create the recipe 1, you must select the field by pressing the **1** key in the **Select program** column first; the key of the selected recipes will be highlighted in green; then you must enter a brief description (max. 8 digit long) of the program you are going to create in the blank field on the right; as soon as you press the field an alphanumeric keypad will appear on the display. Press the **ENT** key to confirm the entry.



Now you must set the target position of each individual axle. The target position is the commanded position, i.e. the position that each actuator (that is, each axle) is commanded to reach.

To do this you must enter the required target position in the **Target** column on the right next to each actuator.

We suggest entering the **Node control** page (see the "5.6 Node control page" section on page 26), setting the required target value and then checking the movement of each axle by using the manual movement control keys. After having refined the movement of the axle, move back to the **Home** page and then set the target position (if the current position of the axle -it is displayed under the **Actual position** field- tallies with the set target position, i.e. you



moved the axle to the target position, then you have just to press the key to copy the value from the **Actual position** field and paste it into the **Target** field, so saving it in the selected recipe).



The **ACTIVATE RECIPE** key activates the selected recipe and commands the axles to reach the set target positions. No password is required to use this key.

To activate a recipe and start the positioning of the axles, select the required recipe by pressing one of the keys (from **1** to **10**) in the **Select program** column, then press the **ACTIVATE RECIPE** key.

**WARNING**

As soon as you press the **ACTIVATE RECIPE** key the axles start moving. Before pressing the key please make sure that the movement can be achieved with absolute safety and no risk to cause injuries to the operators and damages to the equipment can arise.



Press the **STOP** key to stop the positioning of the axles.

**WARNING**

Please note that pressing the **STOP** key will cause a normal and sequential halt of the actuators to be forced; the actuators will be commanded to stop from the first to the last one in the network and they will respect the set deceleration values; thus their stop will not be immediate.

**WARNING**

A safety push-button for emergency power off must be installed to shut off the motor power supply and immediately stop the axles in case of emergency situations.

5.11 Firmware upgrade

This procedure allows the operator to upgrade the firmware of the HMI interface and download upgrading data to the flash memory.

The firmware is a software program which controls the functions and operation of a device; the firmware program, sometimes referred to as "user program", is stored in the flash memory integrated inside the interface. The interface is designed so that the firmware can be easily updated by the user himself. This allows Lika Electronic to make new improved firmware programs available during the lifetime of the product.

The firmware upgrading program consists of a single file having .PRP extension. It is released by Lika Electronic Technical Assistance & After Sale Service.

**WARNING**

The interface firmware upgrading process has to be accomplished by skilled and competent personnel. If the upgrade is not performed according to the instructions provided or a wrong or incompatible firmware program is installed then the device may not be updated correctly, in some cases preventing the interface from working.

If you are not confident that you can perform the upgrade successfully please contact Lika Electronic Technical Assistance & After Sale Service.

To upgrade the firmware program please proceed as follows:

1. switch the power supply off;
2. copy the .PRP file provided by Lika Electronic onto a USB flash drive and then plug the USB flash drive into the USB service port 2 (Figure 3);

**WARNING**

The USB flash drive needs to be formatted and contain only the .PRP file.

3. switch the power supply on while simultaneously pressing on the top left corner of the screen (see the Figure below) and keep it pressed for 3 seconds until you hear a short beep;



- the **System Loader** page will appear on the display;



- press the **RUN** key;
- the **Panel Setup** page will be displayed; press the **UPDATE FROM FILE** key;



- once you press the **UPDATE FROM FILE** key the **Open** dialogue box appears on the screen: you must open the folder where the firmware upgrading .PRP file released by Lika Electronic is located;
- select the .PRP file and confirm the choice by pressing the **OPEN** button, the dialogue box closes;
- the process will start and a status bar will appear to show the installation progress;

**WARNING**

Do not switch the power supply off during installation!

10. as soon as the operation is carried out, if it has been completed successfully the **Panel Setup** page will be displayed;
11. turn the power supply off and then on again to start the panel in the normal display mode.

This page intentionally left blank

Document release	Release date	Description	HW	SW	Interface
1.0	09.09.2015	First issue		2.1	
1.1	22.04.2016	New software version		2.2	
1.2	07.11.2016	New software version, RD6 actuator implemented		2.3	



Dispose separately

lika

Lika Electronic

Via S. Lorenzo, 25 • 36010 Carrè (VI) • Italy

Tel. +39 0445 806600

Fax +39 0445 806699



info@lika.biz • www.lika.biz