

UDF LED multi strobe beacon

- Ø 60 mm LED multi-strobe beacon
- Good signalling effect
- Modular design
- High degree of protection IP 66 & impact resistance IK08
- Modern LED technology and electronics
- 2 different strobe patterns, can be switched externally
- For industrial and general applications
- User-friendly connection technology

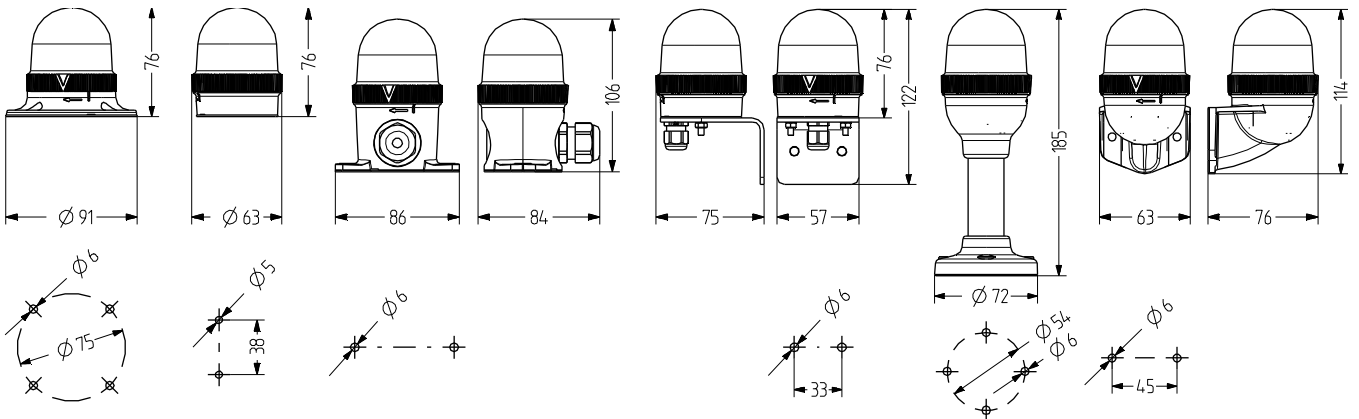

TECHNICAL DATA

Housing	Ø 60 mm, Polycarbonate black (RAL 9005)
Lens	Polycarbonate, ribbed inside orange, red, clear, blue, green or yellow
Type of mounting	horizontal, vertical or Tube mounting
Cable entry	depending on base
Connection technology	Screw terminal 2,5 mm ²
Leakage current	0,003 A (PLC-suitable)
Beacon type	LED multi strobe beacon

Light source	12 LEDs
Strobe/flash frequency	6x strobe/multi strobe 1 Hz
Duty cycle	100 %
Service life	Light source: >50.000 h
Operating temperature	-30°C/+60°C
Degree of protection	IP66 & UL Type 4/4x/13
Impact resistance	IK08
Weight	52 g

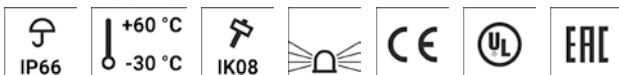

UDF

ORDER DATA - LENS

Lens colour	Nominal voltage	Voltage range (V)	Nominal current (A)	Order number
orange	24 V AC/DC	18-27 V AC	0,120	858 511 405
		20-32 V DC		
	110-120 V AC	75-132	0,033	858 511 310
red	24 V AC/DC	18-27 V AC	0,120	858 512 405
		20-32 V DC		
	110-120 V AC	75-132	0,033	858 512 310
clear	24 V AC/DC	18-27 V AC	0,120	858 514 405
		20-32 V DC		
	110-120 V AC	75-132	0,033	858 514 310
blue	24 V AC/DC	18-27 V AC	0,120	858 515 405
		20-32 V DC		
	110-120 V AC	75-132	0,033	858 515 310
green	24 V AC/DC	18-27 V AC	0,120	858 516 405
		20-32 V DC		
	110-120 V AC	75-132	0,033	858 516 310
yellow	24 V AC/DC	18-27 V AC	0,120	858 517 405
		20-32 V DC		
	110-120 V AC	75-132	0,033	858 517 310
	230-240 V AC	150-264	0,033	858 517 313



Strobe



UMW



UMF



UMV



UMR



UNL



UNW

ORDER DATA - BASE

Type	Type of accessory	Tube length	Weight	Order number
UMW	Base for vertical mounting, with internal mounting holes			858 500 900
UMF	Base for horizontal mounting, with external mounting holes		80 g	858 510 900
UMV	Base for vertical mounting		87 g	858 520 900
UMR	Tube base for horizontal mounting, with aluminium tube/plastic foot	100 mm		858 532 900
		250 mm		858 533 900
UNL	Base for horizontal mounting, with side cable entry		99 g	858 515 900
UNW	Tube base for NPT 1/2" tube mounting			858 540 900



UVS



XWR



PV1

ACCESSORIES

Type	Type of accessory	Weight	Order number
UVS	Bracket with UMW cable entry from bottom (incl. cable gland M12 x 1.5)	157 g	858 550 900
XWR	Bracket for vertical mounting of TMR/UMR tube base	95 g	900 600 900
PV1	Ventilation element for optimum pressure equalisation, protection against condensation forming, compatible with TMW, TMF, TNL, UMW, UMF, UNL		859 100 000